

CABLED JACKS

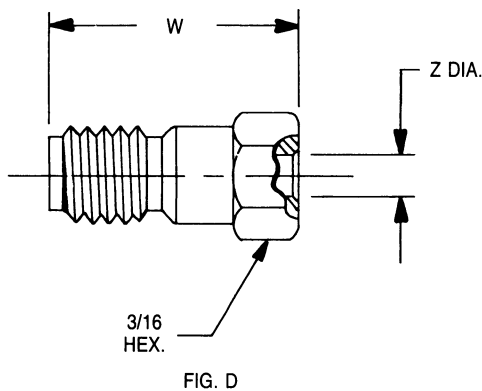
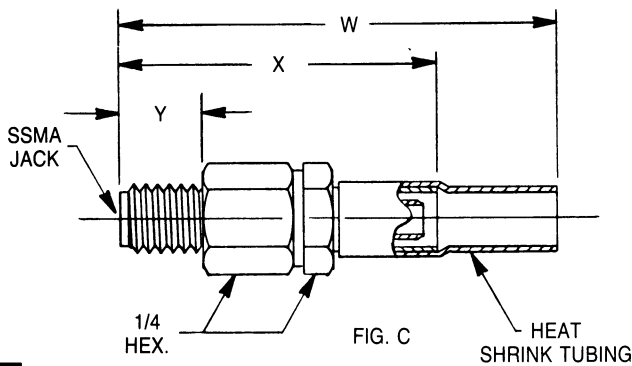
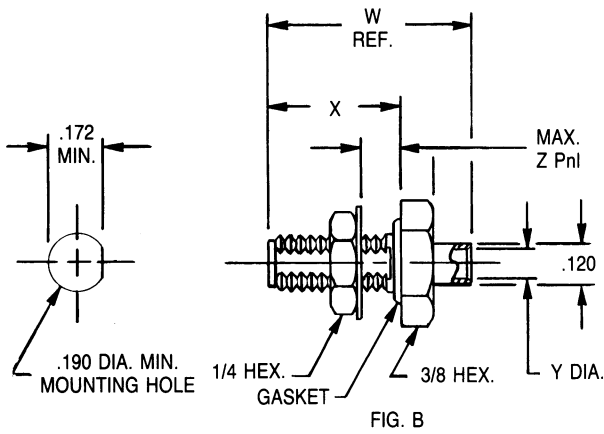
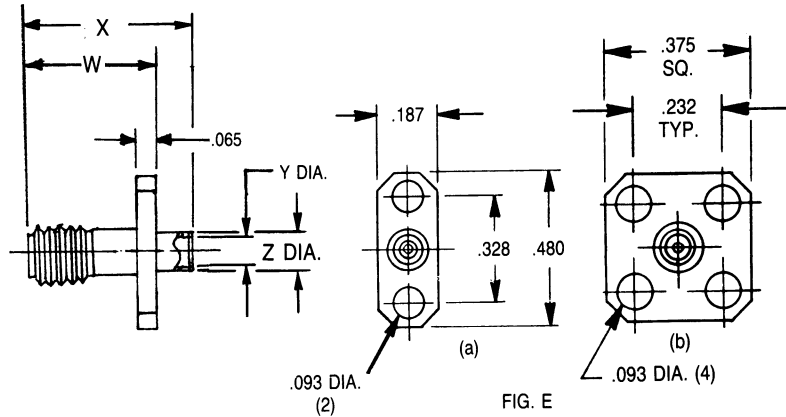
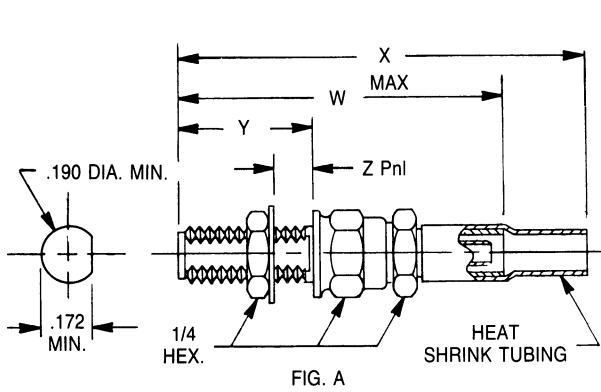

Cable Type	Part Number	Fig.	Dimensions (inches)			
			W	X	Y	Z
26 GHz DIRECT SOLDER STRAIGHT CABLE JACK						
RG 405 (.085)	S/M 2722-6007	D	.500			.090
RG 405 (.085)	S/M 2721-6002	B				
STRAIGHT CABLE JACK (Direct Crimp)						
RG 174/188/316	S/M 2720-6001	C	1.052	.660	.235	
RG 178/196	S/M 2720-6002	C	1.052	.660	.235	
STRAIGHT CABLE JACK (Crimp Clamp)						
RG 178/196	S/M 2743-6005	C	.900	1.240	.235	
RG 174/188/316	S/M 2743-6006	C	1.025	1.240	.235	
26 GHz BULKHEAD MOUNT DIRECT SOLDER						
RG 405 (.085)	S/M 2746-6001	B	.645	.450	.090	.125
BULKHEAD MOUNT CABLE JACK						
RG 174/188/316	S/M 2743-6004	A	1.180	1.372	.450	.125
RG 178/196	S/M 2743-6002	A	1.050	1.372	.450	.125
26 GHz 2 HOLE PANEL MOUNT						
RG 405 (.085)	S/M 2733-6003	E(a)	.375	.500	.090	.120
40 GHz 2 HOLE PANEL MOUNT						
.047 SemiRigid	S/M 2733-6402	E(a)	.375	.500	.088	.052
RG 405 (.085)	S/M 2722-6402	E(a)	.375	.500	.120	.090
26 GHz 4 HOLE PANEL MOUNT						
RG 405 (.085)	S/M 2733-6002	E(b)	.375	.500	.090	.120
40 GHz 4 HOLE PANEL MOUNT						
.047 SemiRigid	S/M 2733-6401	E(b)	.375	.500	.088	.052
RG 405 (.085)	S/M 2722-6401	E(b)	.375	.500	.120	.090

ADD "SF" TO PART NUMBER FOR STAINLESS FINISH VERSION.

RIGHT ANGLE CABLE PLUGS

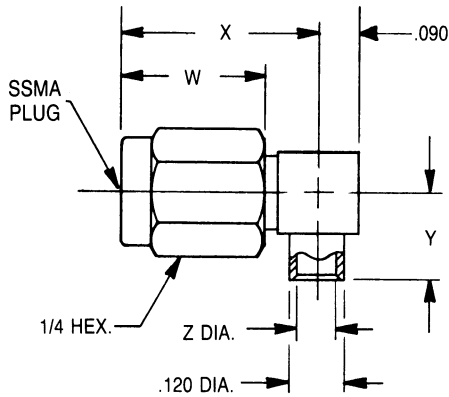

FIG. A

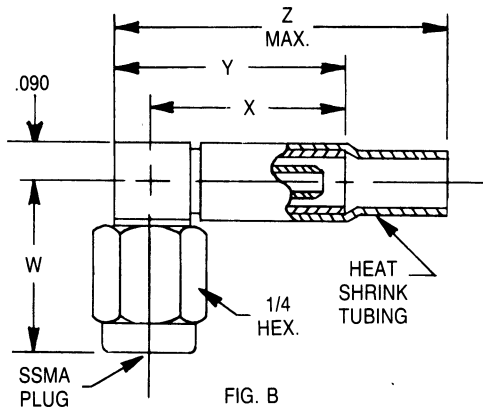

FIG. B

Cable Type	Part Number	FIG.	Dimensions (Inches)			
			W	X	Y	Z
STANDARD PERFORMANCE DIRECT SOLDER						
RG 405 (.085)	S/M 2712-6001	A	.330	.460	.205	.090
RG 405 (.085)	S/M 2715-4002	A	.330	.450	.215	.090
STANDARD PERFORMANCE CRIMP ATTACHMENT						
RG 178/196	S/M 2713-6007	B	.460	.400	.500	.900
RG 174/188/316	S/M 2713-6008	B	.460	.525	.625	.900
STANDARD PERFORMANCE SOLDER ATTACHMENT						
RG 178/196	S/M 2713-6011	B	.460	.400	.500	.900
RG 178/196	S/M 2713-6003	B	.460	.440	.540	1.00
RG 174/188/316	S/M 2713-6016	B	.460	.525	.625	.900
RG 174/188/316	S/M 2713-6009	B	.460	.440	.540	1.00

ADD SUFFIX SF TO PART NUMBER FOR STAINLESS FINISH VERSION

RECEPTACLES

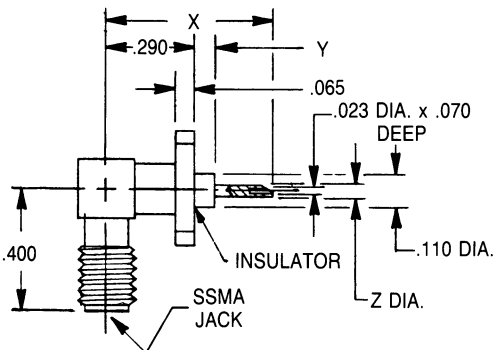
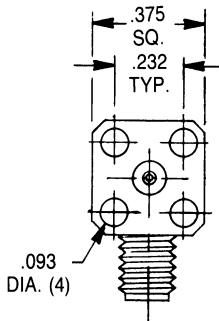
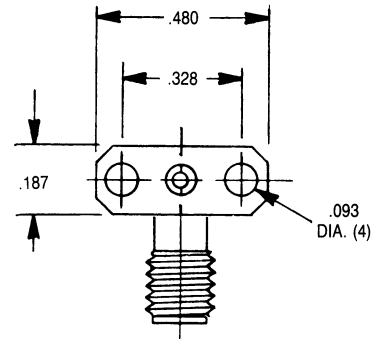

FIG. C



MOUNTING (a)



MOUNTING (b)

RECEPTACLES

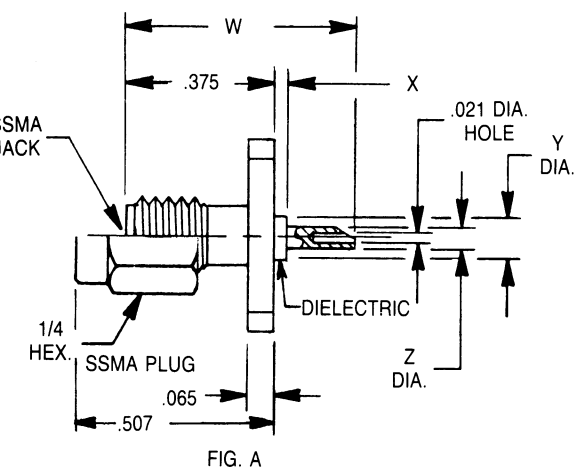
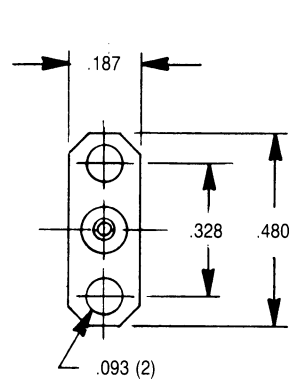
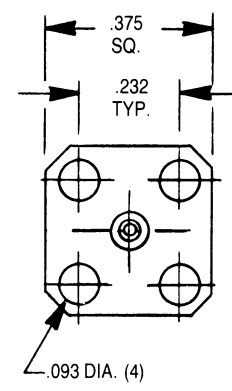

FIG. A



(a)



(b)

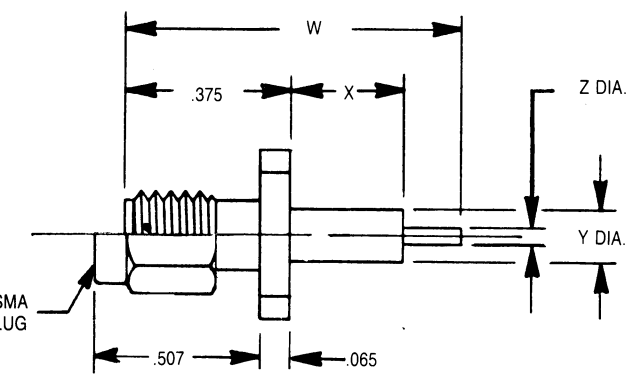

FIG. B

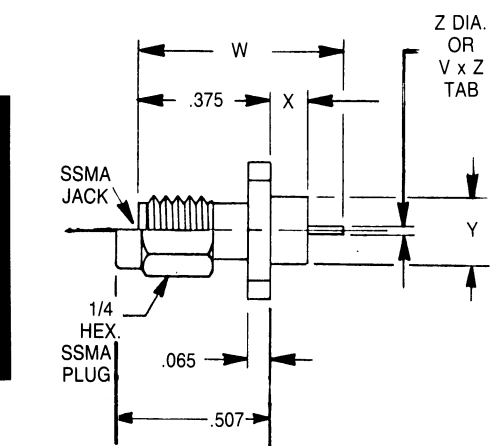

FIG. C

Contact Type	Part Number	Fig.	Dimensions (inches)				
			V	W	X	Y	Z
2 HOLE STRAIGHT JACK (Solder Pot)							
Captive	S/M 2750-6024	A(a)		.575	.035	.110	.034
Captive	S/M 2750-6081	A(b)		.575	0	N/A	.034
4 HOLE STRAIGHT JACK (Round Conductor)							
Captive	S/M 2750-6007	B(b)		.875	.375	.110	.034
Loose	S/M 2750-6006	B(b)		.875	.375	.110	.034
4 HOLE STRAIGHT JACK WITH GASKET (Round Conductor)							
Captive	S/M 2750-6012	A(b)		.490	0	N/A	.015
Captive	S/M 2750-6131	C(b)		.583	.093	.145	.015
Captive	S/M 2750-6132	C(b)		.615	.125	.145	.015
Captive	S/M 2750-6133	C(b)		.677	.187	.145	.015
4 HOLE STRAIGHT JACK WITH TAB							
Loose	S/M 2750-6044	C(b)	.004	.475	0	N/A	.034
Captive	S/M 2750-6045	C(b)	.004	.475	0	N/A	.034
Captive	S/M 2750-6104	C(b)	.005	.568	.093	.185	.020
Captive	S/M 2750-6105	C(b)	.005	.600	.125	.185	.020
Captive	S/M 2750-6106	C(b)	.005	.662	.187	.185	.020
2 HOLE STRAIGHT JACK WITH TAB							
Loose	S/M 2750-6042	C(a)	.005	.475	0	N/A	.020
Captive	S/M 2750-6043	C(a)	.005	.475	0	N/A	.020
2 HOLE STRAIGHT PLUG (Round Conductor)							
Captive	S/M 2755-6202	A(a)		.707	0	N/A	.034

ADD SUFFIX SF FOR STAINLESS FINISH VERSION.

RECEPTACLES (Continued)

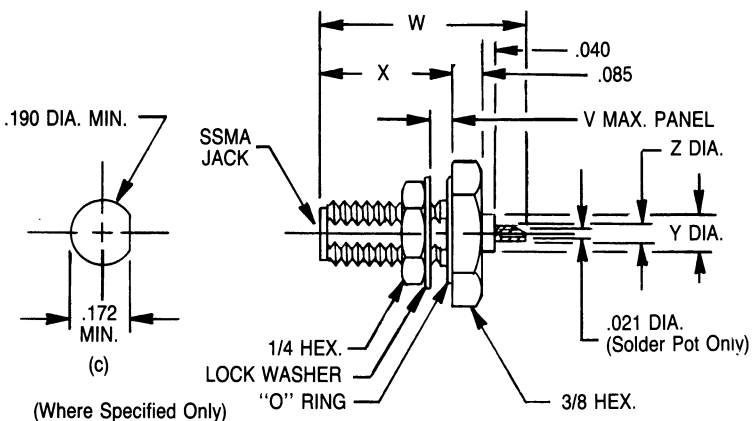

FIG. D

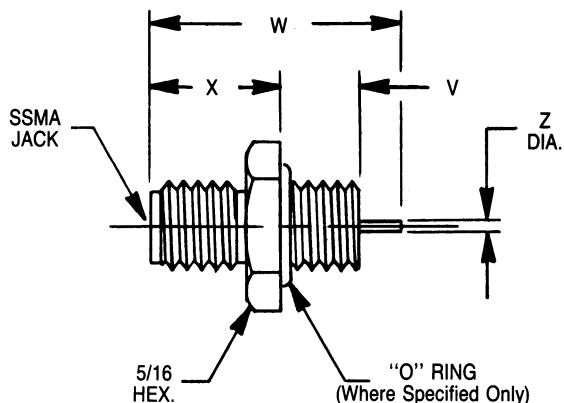

FIG. E

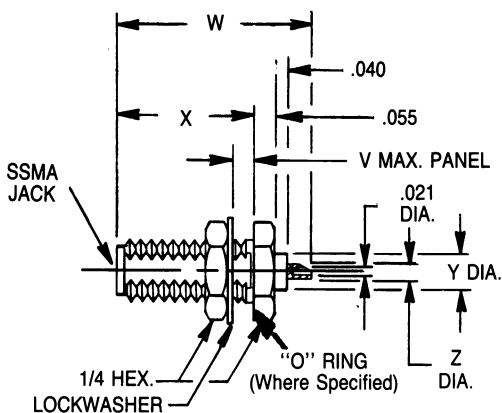

FIG. F

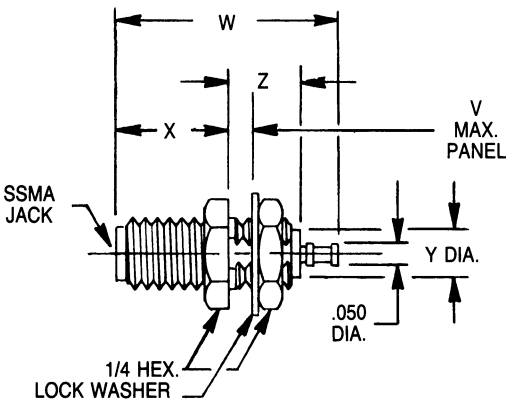
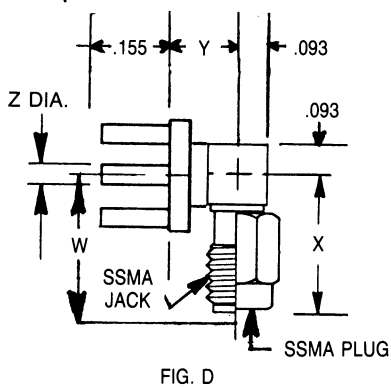
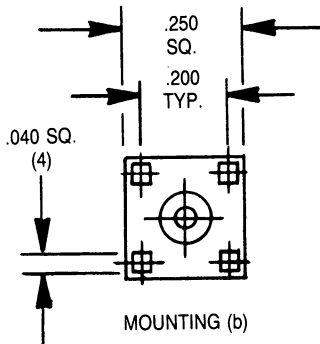
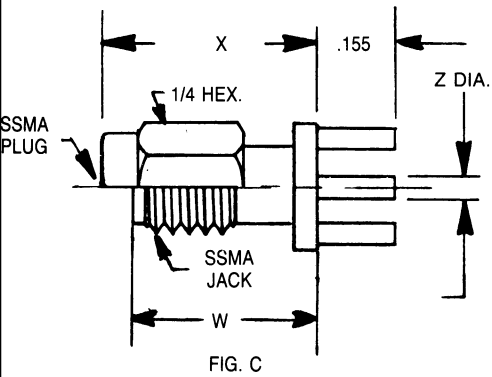
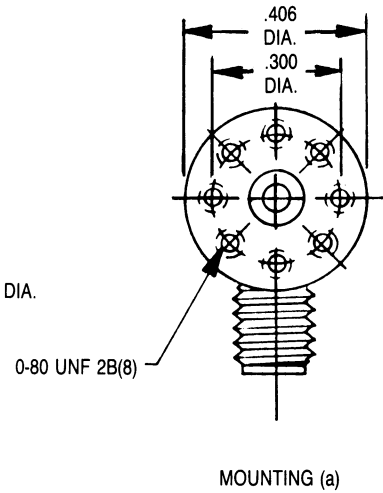
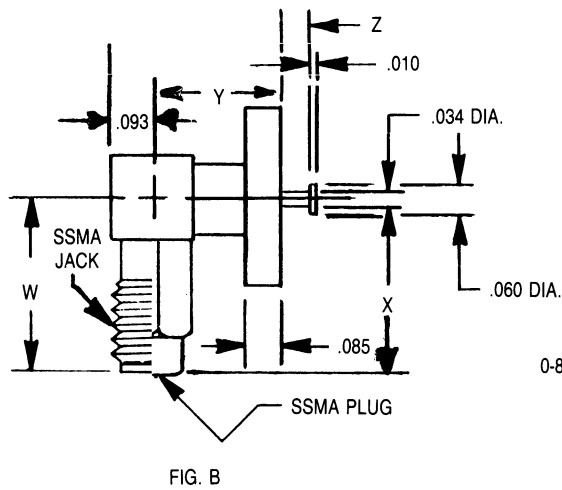
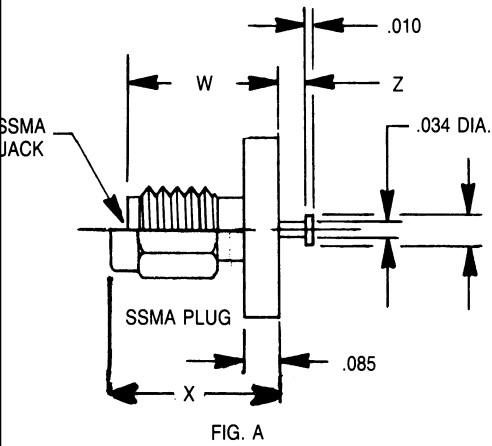

FIG. G

Mounting & Contact Type	Part Number	FIG.	Dimensions (Inches)				
			V	W	X	Y	Z
4 HOLE STRAIGHT PLUGS (Round Conductor)							
Captive	S/M 2755-6022	A(b)		.707	0	n/a	.034
Loose	S/M 2755-6091	B(b)		.995	.330	.110	.034
Captive	S/M 2755-6081	B(b)		.995	.330	.110	.034
4 HOLE STRAIGHT PLUGS (Round Conductor with Gasket)							
Captive	S/M 2755-6017	B(b)		.632	0	n/a	.015
HERMETICALLY SEALED BULKHEAD MOUNTING with O ring (Round Conductor)							
Rear Mount	S/M 2770-6011	D(c)	.093	.615	.415	n/a	.015
Front Mount Screw-In	S/M 2771-6008	E	.175	.600	.300	n/a	.015
BULKHEAD MOUNTING (Solder Pot not hermetic)							
Rear Mount w/ O Ring	S/M 2770-6042	D(c)	.062	.600	.390	.110	.034
Rear Mount	S/M 2770-6003	D(c)	.093	.600	.420	.110	.021
BULKHEAD MOUNTING WITH TURRET (not hermetic)							
Front Mount	S/M 2771-6007	G(c)	.062	.600	.300	.110	.175
Front Mount	S/M 2775-4001	G(c)	.062	.600	.300	--	--

ADD SUFFIX SF FOR STAINLESS FINISH VERSION

STRIPLINE & PRINTED CIRCUIT RECEPTACLES



TYPE	Part Number	Fig.	Dimensions (Inches)			
			W	X	Y	Z
NON HERMETIC STRIPLINE Captivated Contact						
ST. JACK	S/M 2780-6004	A(a)	.360	--	--	.062
ST. JACK	S/M 2780-6001	A(a)	.360	--	--	.031
RT. ANG JACK	S/M 2782-6001	B(a)	.400	--	.307	.062
RT. ANG JACK	S/M 2782-6003	B(a)	.400	--	.307	.031
NON HERMETIC PRINTED CIRCUIT Captivated Contact						
ST. JACK	S/M 2785-6004	C(b)	.375	--	--	.034
ST. PLUG	S/M 2785-6016	C(b)	--	.507	--	.034

ADD SUFFIX SF FOR STAINLESS FINISH VERSION

FIELD REPLACEABLE

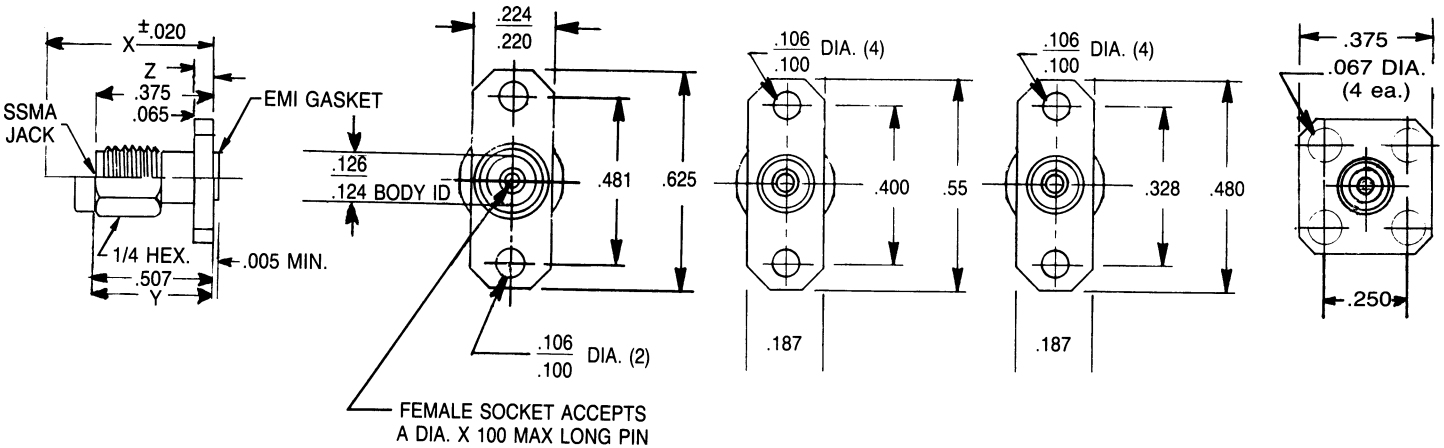

FIG. A

MTNG. (a)

MTNG. (b)

MTNG. (c)

MTNG. (d)

FIG.	DIM A PIN DIA	2 HOLE .223 x .625 Mtnng a	2 HOLE .187 x .550 Mtnng b	2 HOLE .187 x .480 Mtnng c	4 HOLE .375 x .375 Mtnng d	DIMENSIONS (Inches)		
						X	Y	Z
SSMA STRAIGHT JACKS								
A	.013/.011 NO GASKET WITH GASKET			S/M 2750-6421† S/M 2750-6420†	S/M 2750-6406† S/M 2750-6403†	-- --	.375 .375	.065 .065
A	.017/.014 NO GASKET WITH GASKET			S/M 2750-6424† S/M 2750-6407†	S/M 2750-6409† S/M 2750-6404†	-- --	.375 .375	.065 .065
A	.021/.018 NO GASKET WITH GASKET			S/M 2750-6425† S/M 2750-6408†	S/M 2750-6410† S/M 2750-6405†	-- --	.375 .375	.065 .065
SSMA STRAIGHT PLUGS								
A	.013/.011 NO GASKET WITH GASKET			S/M 2755-6477†	S/M 2755-6471†	.507	--	.065
A	.017/.014 NO GASKET WITH GASKET			S/M 2755-6479†	S/M 2755-6472†	.507	--	.065
A	.021/.018 NO GASKET WITH GASKET			S/M 2755-6480†	S/M 2755-6473†	.507	--	.065

† 40 GHz Design
STANDARD STOCKED ITEM IS STAINLESS FINISH. ADD SUFFIX SF FOR STAINLESS FINISH VERSION.

ADAPTERS

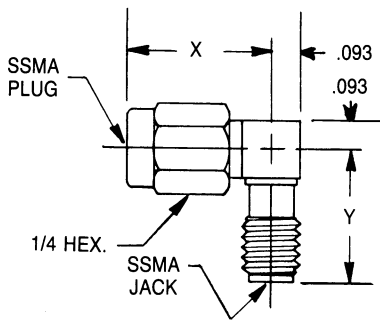

FIG. A

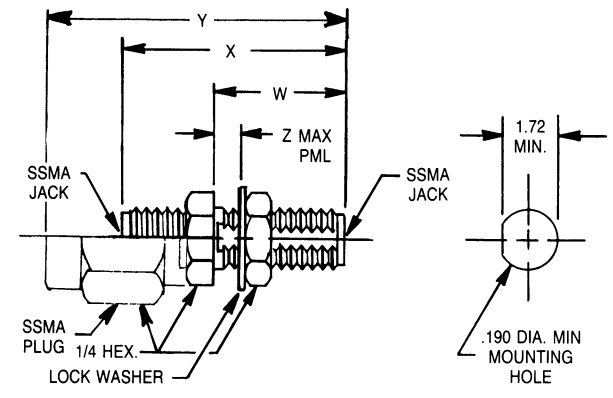

FIG. C

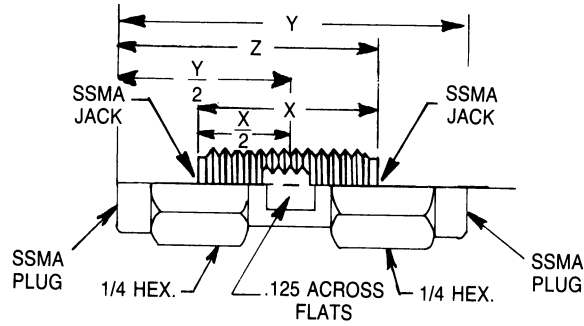

FIG. B

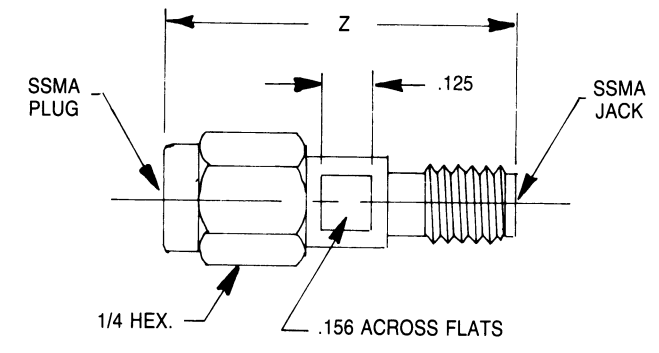

FIG. D

	STANDARD SSMA				40 GHz HIGH PERFORMANCE SSMA				DIMENSIONS (INCHES)			
	JACK		PLUG		JACK		PLUG		W	X	Y	Z
	PART NO	FIG	PART NO	FIG	PART NO	FIG	PART NO	FIG				
NON HERMETIC ADAPTERS (BRB)												
ST. JACK	S/M 2792-6010	B			S/M 2772-6401	B				.50		
ST. PLUG	S/M 2797-6003	D	S/M 2793-6010	B			S/M 2773-6401	A		.875	.840	
RT ANG. JACK			S/M 2794-6003	A						.470	.428	
RT ANG PLUG	S/M 2794-6003	A								.470	.428	
NON HERMETIC BULKHEAD ADAPTERS (BRB)												
ST. JACK	S/M 2790-6005	C								.40	.700	.070

Add Suffix SF to Part No. for Stainless Finish Version

TERMINATIONS

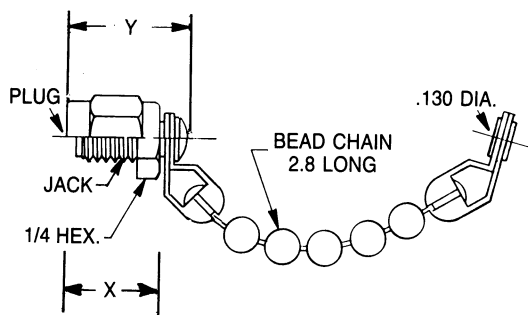

FIG. A

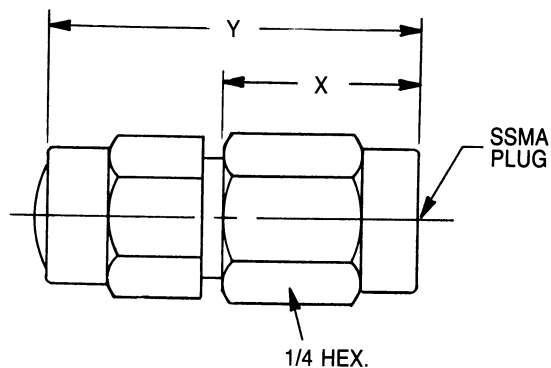

FIG. B

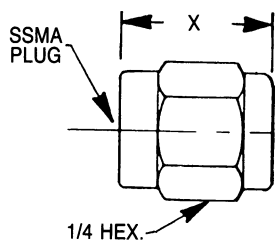

FIG. C

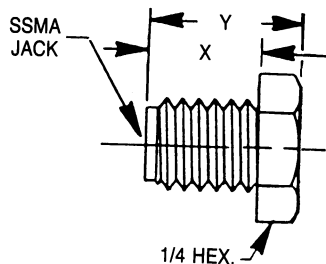

FIG. D

TYPE & FEATURE	PART NUMBER	MAX FREQ (GHz)	MAX SWR	MAX PWR (W)	DIMEN. (inches)		
					FIG.	X	Y
PLAIN (NO CHAINS)							
50 Ohm Termination	S/M 8027-6008SF	18	1.23	0.5	B	.330	.615
Plug Dust Cap (for Jack Cntr)	S/M 2798-6002	--	--	--	C	.330	
Jack Dust Cap (for Plug Cntr)	S/M 2799-6001	--	--	--	D	.235	.375
WITH CHAINS							
Plug Dust Cap (for Jack Cntr)	S/M 2798-6013	--	--	--	A		.410
Jack Dust Cap (for Plug Cntr)	S/M 2799-6004	--	--	--	A	.235	.400

ADD SUFFIX SF TO PART NUMBER FOR STAINLESS FINISH VERSION